

# Link-Belt®

## CONSTRUCTION EQUIPMENT

# HTC - 8670 LB

CRANE RATING MANUAL  
4 - SECTION POWER BOOM

SEE NUMBER

F250-4218

For Replacement, Order Part Number: F2P0159  
(080399)

© Link-Belt is a registered trademark.

# Table Of Contents

## Page Contents

3-4	Operating Instructions
5	General Dimensions
5	Tire Inflation
5	Pontoon Loadings
6	Boom Mode "A" and "B"
7	Winch Performance
7	Wire Rope Capacity
7	Hydraulic Circuit Pressure Settings
8	Working Areas
8	Capacity Deductions for Auxiliary Load Handling Equipment

## Fully Extended Outriggers

9	Working Range Diagram, 0# CTWT
10-14	Lifting Capacities, 0# CTWT
15	Working Range Diagram, 4,000# CTWT
16-22	Lifting Capacities, 4,000# CTWT
23	Working Range Diagram, 8,000# CTWT
24-32	Lifting Capacities, 8,000# CTWT
33	Working Range Diagram, 12,000# CTWT
34-42	Lifting Capacities, 12,000# CTWT
43	Working Range Diagram, 16,000# CTWT
44-52	Lifting Capacities, 16,000# CTWT

## Intermediate Extended Outriggers

53	Working Range Diagram, 4,000# CTWT
54-56	Lifting Capacities, 4,000# CTWT
57	Working Range Diagram, 8,000# CTWT
58-60	Lifting Capacities, 8,000# CTWT
61	Working Range Diagram, 12,000# CTWT
62-66	Lifting Capacities, 12,000# CTWT
67	Working Range Diagram, 16,000# CTWT
68-72	Lifting Capacities, 16,000# CTWT

## Fully Retracted Outriggers

73	Working Range Diagram, 8,000# CTWT
74-76	Lifting Capacities, 8,000# CTWT
77	Working Range Diagram, 12,000# CTWT
78-80	Lifting Capacities, 12,000# CTWT

## On Tires

81	Working Range Diagram, 8,000# CTWT
82-86	Lifting Capacities, 8,000# CTWT
87	Working Range Diagram, 12,000# CTWT
88-92	Lifting Capacities, 12,000# CTWT
93	Working Range Diagram, 16,000# CTWT
94-97	Lifting Capacities, 16,000# CTWT
98	Patent Information



## WARNING

**READ AND UNDERSTAND THE OPERATOR'S AND SAFETY MANUALS AND THE FOLLOWING INSTRUCTIONS AND RATED LIFTING CAPACITIES BEFORE OPERATING THE CRANE. OPERATION WHICH DOES NOT FOLLOW THESE INSTRUCTIONS MAY RESULT IN AN ACCIDENT.**

### OPERATING INSTRUCTIONS

#### GENERAL:

1. Rated lifting capacities in pounds as shown on lift charts pertain to this crane as originally manufactured and normally equipped. Modifications to the crane or use of optional equipment other than that specified can result in a reduction of capacity.
2. Construction equipment can be dangerous if improperly operated or maintained. Operation and maintenance of this crane must be in compliance with the information in the Operator's, Parts, and Safety Manuals supplied with this crane. If these manuals are missing, order replacements through the distributor.
3. The operator and other personnel associated with this crane shall read and fully understand the latest applicable American National Standards ASME B30.5 safety standards for cranes.
4. The rated lifting capacities are based on crane standing level on firm supporting surface.

#### SET UP:

1. The crane shall be leveled on a firm supporting surface. Depending on the nature of the supporting surface, it may be necessary to have structural supports under the outrigger pontoons or tires to spread the load to a larger bearing surface.
2. When making lifts on outriggers, all tires must be free of supporting surface. All outrigger beams must be extended to the same length; fully retracted, intermediate extended, or fully extended. The front bumper outrigger must be properly extended.
3. When operating on fully retracted outriggers, do not exceed 67° maximum boom angle with 16,000 lb. counterweight, or 73° maximum boom angle with 12,000 lb. counterweight. Loss of backward stability will occur causing a backward tipping condition.
4. When making lifts on tires, they must be inflated to the recommended pressure. (See Operation note 20 and Tire Inflation.)
5. Before swinging boom to over side position on tires, or on fully retracted outriggers where capacities are not published, boom sections must be fully retracted and 50° boom angle maintained.

6. For required parts of line, see Wire Rope Capacity and Winch Performance.
7. Before setting up on outriggers or tires, refer to Working Range Diagrams and rated lifting capacities to determine allowable crane configurations.

#### OPERATION:

1. Rated lifting capacities at rated radius shall not be exceeded. Do not tip the crane to determine allowable loads. For concrete bucket operation, weight of bucket and load shall not exceed 80% of rated lifting capacities. For clamshell bucket operation, weight of bucket and bucket contents is restricted to a maximum weight of 7,000 pounds or 80% of rated lifting capacity, whichever is less. For magnet operation, weight of magnet and load is restricted to a maximum weight of 7,000 pounds or 80% of rated lifting capacity, whichever is less. For clamshell and magnet operation, maximum boom length is restricted to 60 ft. and the boom angle is restricted to a minimum of 35 degrees. Lifts with either fly erected is prohibited for both clam and magnet operation.
2. Rated lifting capacities shown on fully extended outriggers do not exceed 85% of the tipping loads. Rated lifting capacities shown on intermediate extended or fully retracted outriggers are determined by the formula, rated load = (tipping load - 0.1 X load factor)/1.25. Rated lifting capacities shown on tires do not exceed 75% of the tipping loads. Tipping loads are determined by SAE crane stability test code J-765.
3. Rated lifting capacities in the shaded areas are based on structural strength or hydraulic limitations and have been tested to meet minimum requirements of SAE J-1063 cantilevered boom crane structures - method of test. The rated lifting capacities in non-shaded areas are based on stability ratings. Some capacities are limited by a maximum obtainable 78° boom angle.
4. Rated lifting capacities include the weight of the hook ball/block, slings, bucket, magnet and auxiliary lifting devices. Their weights must be subtracted from the listed rated capacity to obtain the net load which can be lifted. Rated lifting capacities include the deduct for either fly stowed on the base of the boom. For deducts of either fly erected, but not used, see Capacity Deductions For Auxiliary Load Handling Equipment.



## WARNING

**READ AND UNDERSTAND THE OPERATOR'S AND SAFETY MANUALS AND THE FOLLOWING INSTRUCTIONS AND RATED LIFTING CAPACITIES BEFORE OPERATING THE CRANE. OPERATION WHICH DOES NOT FOLLOW THESE INSTRUCTIONS MAY RESULT IN AN ACCIDENT.**

### OPERATING INSTRUCTIONS

#### GENERAL:

1. Rated lifting capacities in pounds as shown on lift charts pertain to this crane as originally manufactured and normally equipped. Modifications to the crane or use of optional equipment other than that specified can result in a reduction of capacity.
2. Construction equipment can be dangerous if improperly operated or maintained. Operation and maintenance of this crane must be in compliance with the information in the Operator's, Parts, and Safety Manuals supplied with this crane. If these manuals are missing, order replacements through the distributor.
3. The operator and other personnel associated with this crane shall read and fully understand the latest applicable American National Standards ASME B30.5 safety standards for cranes.
4. The rated lifting capacities are based on crane standing level on firm supporting surface.

#### SET UP:

1. The crane shall be leveled on a firm supporting surface. Depending on the nature of the supporting surface, it may be necessary to have structural supports under the outrigger pontoons or tires to spread the load to a larger bearing surface.
2. When making lifts on outriggers, all tires must be free of supporting surface. All outrigger beams must be extended to the same length; fully retracted, intermediate extended, or fully extended. The front bumper outrigger must be properly extended.
3. When operating on fully retracted outriggers, do not exceed 67° maximum boom angle with 16,000 lb. counterweight, or 73° maximum boom angle with 12,000 lb. counterweight. Loss of backward stability will occur causing a backward tipping condition.
4. When making lifts on tires, they must be inflated to the recommended pressure. (See Operation note 20 and Tire Inflation.)
5. Before swinging boom to over side position on tires, or on fully retracted outriggers where capacities are not published, boom sections must be fully retracted and 50° boom angle maintained.

6. For required parts of line, see Wire Rope Capacity and Winch Performance.
7. Before setting up on outriggers or tires, refer to Working Range Diagrams and rated lifting capacities to determine allowable crane configurations.

#### OPERATION:

1. Rated lifting capacities at rated radius shall not be exceeded. Do not tip the crane to determine allowable loads. For concrete bucket operation, weight of bucket and load shall not exceed 80% of rated lifting capacities. For clamshell bucket operation, weight of bucket and bucket contents is restricted to a maximum weight of 7,000 pounds or 80% of rated lifting capacity, whichever is less. For magnet operation, weight of magnet and load is restricted to a maximum weight of 7,000 pounds or 80% of rated lifting capacity, whichever is less. For clamshell and magnet operation, maximum boom length is restricted to 60 ft. and the boom angle is restricted to a minimum of 35 degrees. Lifts with either fly erected is prohibited for both clam and magnet operation.
2. Rated lifting capacities shown on fully extended outriggers do not exceed 85% of the tipping loads. Rated lifting capacities shown on intermediate extended or fully retracted outriggers are determined by the formula, rated load = (tipping load - 0.1 X load factor)/1.25. Rated lifting capacities shown on tires do not exceed 75% of the tipping loads. Tipping loads are determined by SAE crane stability test code J-765.
3. Rated lifting capacities in the shaded areas are based on structural strength or hydraulic limitations and have been tested to meet minimum requirements of SAE J-1063 cantilevered boom crane structures - method of test. The rated lifting capacities in non-shaded areas are based on stability ratings. Some capacities are limited by a maximum obtainable 78° boom angle.
4. Rated lifting capacities include the weight of the hook ball/block, slings, bucket, magnet and auxiliary lifting devices. Their weights must be subtracted from the listed rated capacity to obtain the net load which can be lifted. Rated lifting capacities include the deduct for either fly stowed on the base of the boom. For deducts of either fly erected, but not used, see Capacity Deductions For Auxiliary Load Handling Equipment.

5. Rated lifting capacities are based on freely suspended loads. No attempt shall be made to move a load horizontally on the ground in any direction.
6. Rated lifting capacities are for lift crane service only.
7. Do not operate at radii or boom lengths (minimum or maximum) where capacities are not listed. At these positions, the crane can tip or cause boom failure.
8. The maximum loads which can be telescoped are not definable because of variation in loadings and crane maintenance, but it is permissible to attempt retraction and extension within the limits of the applicable load rating chart.
9. For main boom capacities when either boom length or radius or both are between values listed, proceed as follows:
  - a. For boom lengths not listed, use rating for next longer boom length or next shorter boom length, whichever is smaller.
  - b. For load radii not listed, use rating for next larger radius.
10. The user shall operate at reduced ratings to allow for adverse job conditions, such as: soft or uneven ground, out of level conditions, wind, side loads, pendulum action, jerking or sudden stopping of loads, hazardous conditions, experience of personnel, traveling with loads, electrical wires, etc. Side load on boom or fly is dangerous and shall be avoided.
11. Rated lifting capacities do not account for wind on suspended load or boom. Rated capacities and boom length shall be appropriately reduced as wind velocity approaches 20 mph.
12. When making lifts with auxiliary head machinery, the effective length of the boom increases by 2 ft.
13. Power sections of boom must be extended in accordance with boom mode "A" or "B". In boom mode "B" all power sections must be extended or retracted equally.
14. The least stable rated working area depends on the configuration of the crane set up.
15. Rated lifting capacities are based on correct reeving. Deduction must be made for excessive reeving. Any reeving over minimum required (see Wire Rope Capacity) is considered excessive and must be accounted for when making lifts. Use Working Range Diagram to estimate the extra feet of rope then deduct 1 lb. for each extra foot of wire rope before attempting to lift a load.
16. The loaded boom angle combined with the boom length give only an approximation of the operating radius. The boom angle, before loading, should be greater to account for deflection. For main boom capacities, the loaded boom angle is for reference only. For fly capacities, the load radius is for reference only.
17. For fly capacities with main boom length less than 127 ft. and greater than 100 ft., the rated capacities are determined by the boom angle using the 127 ft. boom and fly chart. For angles not shown use the next lower boom angle to determine the rated capacity.
18. For fly capacities with main boom length less than 100 ft., the rated capacities are determined by the boom angle only using the 100 ft. boom and fly chart. For angles not shown, use the next lower boom angle to determine the rated capacity.
19. The 41 ft. boom length structural lifting capacities are based on boom fully retracted. If the boom is not fully retracted, do not exceed capacities shown for the 50 ft. boom length.
20. Rated lifting capacities on tires depend on tire capacity, condition of tires, and tire air pressure. On tire capacities require lifting from main boom head only on a smooth and level surface. The boom must be centered over the rear of the crane with two position travel swing lock engaged and the load must be restrained from swinging. Pick and carry operations are restricted to maximum speed of 1 mph. For correct tire pressure, see Tire Inflation.

#### DEFINITIONS:

1. Load Radius: Horizontal distance from a projection of the axis of rotation to the supporting surface, before loading, to the center of the vertical hoist line or tackle with load applied.
2. Loaded Boom Angle:  $\angle$  The angle between the boom base section and horizontal with freely suspended load at the rated radius.
3. Working Area: Area measured in a circular arc about the center line of rotation as shown on the Working Area Diagram.
4. Freely Suspended Load: Load hanging free with no direct external force applied except by the hoist line.
5. Side Load: Horizontal side force applied to the lifted load either on the ground or in the air.
6. No Load Stability Limit: The radius or boom angle beyond which it is not permitted to position the boom because the crane can overturn without any load on the hook.
7. Load Factor: Load applied at the boom tip which gives the same moment effect as the boom mass.

## WINCH PERFORMANCE

Winch Line Pulls			Drum Rope Capacity (Ft.)	
Two Speed Winch				
Wire Rope Layer	Low Speed	High Speed	Layer	Total
	Available Lbs.*	Available Lbs.		
1	17,117	8,453	114	114
2	15,737	7,771	124	238
3	14,563	7,192	134	372
4	13,552	6,692	144	516
5	12,672	6,258	154	670
6	N/A	N/A	164	834

\*Maximum lifting capacity: Type RB Rope=12,920 Lbs. Type ZB Rope=15,600 Lbs.

## WIRE ROPE CAPACITY

Maximum Lifting Capacities Based On Wire Rope Strength			
Parts of Line	3/4"	3/4"	Notes
	Type RB	Type ZB	
1	12,920*	15,600	Capacities shown are in pounds and working loads must not exceed the ratings on the capacity charts in the Crane Rating Manual.  Study Operator's Manual for wire rope inspection procedures.  *Use of swivel end with 1 part of line is not recommended.
2	25,840	31,200	
3	38,760	46,800	
4	51,680	62,400	
5	64,600	78,000	
6	77,520	93,600	
7	90,440	109,200	
8	103,360	124,800	
9	116,280	140,400	
10	129,200	156,000	

LBCE	DESCRIPTION
TYPE RB	18 X 19 Rotation Resistant - Compact Strand - High Strength Preformed, Right Regular Lay
TYPE ZB	36 X 7 Rotation Resistant - Extra Improved Plow Steel - Right Regular Lay

## HYDRAULIC CIRCUIT PRESSURE SETTINGS

Function	Pressure (PSI)
Front And Rear Winch	3500
Outriggers	3000
Boom Hoist	3500
Telescope	3000
Swing	1500
Steering	2000
Bumper Outrigger	650
Pilot Control	500
Counterweight Removal	1700
Swing Park Brake Release	250

# WORKING AREAS

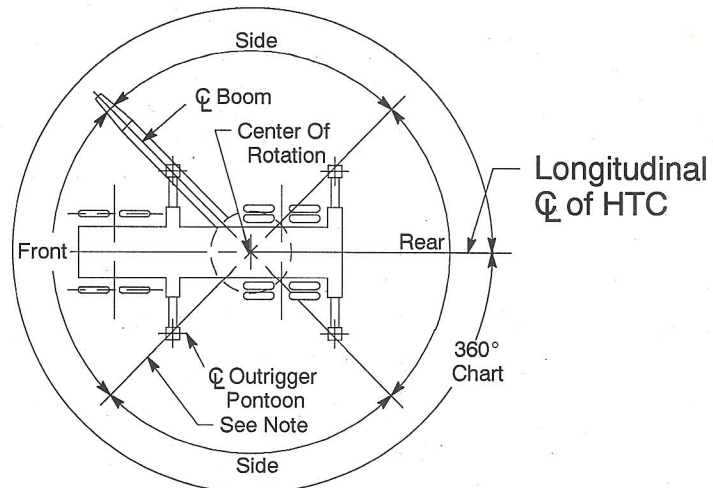

HTC On Outriggers

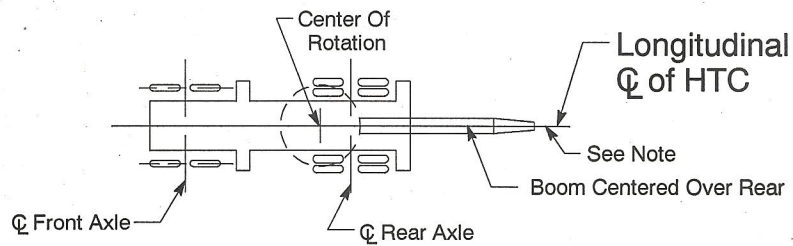

HTC On Tires

**Note: These Lines Determine The Limiting Position Of Any Load For Operation Within Working Areas Indicated.**

## CAPACITY DEDUCTIONS FOR AUXILIARY LOAD HANDLING EQUIPMENT

Load Handling Equipment	Weight (Lbs.)
Auxiliary Head Attached	100
40 Ton Quick Reeve 4 Sheave Hook Block (See Hook Block For Actual Weight)	720
60 Ton Quick Reeve 4 Sheave Hook Block (See Hook Block For Actual Weight)	1100
70 Ton Quick Reeve 5 Sheave Hook Block (See Hook Block For Actual Weight)	1400
8.5 Ton Hook Ball (See Hook Ball For Actual Weight)	360
<b>Lifting From Main Boom With:</b>	
39.5 Ft. Or 67 Ft. Fly Stowed On Base (See Operation Note 4)	0
39.5 Ft. Offset Fly Erected But Not Used	4100
67 Ft. Offset Fly Erected But Not Used	8200
<b>Lifting From 39.5 Ft. Offset Fly With:</b>	
27.5 Ft. Fly Tip Erected But Not Used	<b>PROHIBITED</b>
27.5 Ft. Fly Tip Stowed On 39.5 Ft. Offset Fly	<b>PROHIBITED</b>
<b>Note: Capacity deductions are for Link-Belt supplied equipment only.</b>	